

# WORKHOLDING

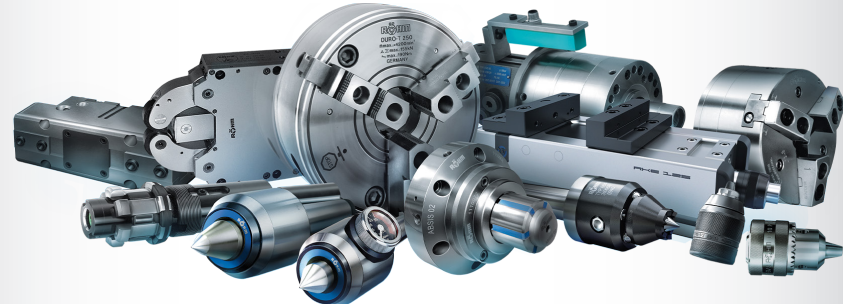

## RÖHM ACCESSORIES

- Duro-T Series: 125-630mm Chucks (Up To 430kN)
- Nc-Compact Centering Vices: 269mm Opening (Up To 25kn)
- Constant Face Drivers: 8-80mm Clamping Diameter
- Live Centers: 0.003mm Maximum Concentricity Deviation
- Tool Clamping Systems



# GANTRY LOADERS



Automation is the Future and Key to profitability.

- Compatible with any CNC Lathe & Controller
- Single & Twin Arm Gantry Models Available
- Available in Stocker & Pallet-Style Loading/Unloading
- Optional Servo-Driven B-Axis with Gripper
- Optional Inbound/Outbound Conveyor & Flip Over Station



BR-03T

# OIL SKIMMERS - DISK TYPE

## WELLTECH

3 programmable modes are the most cost-effective solutions to remove tramp oil from your coolant systems.

- Saves Money by Extending Coolant Life
- Eliminate Foul Odors and Prevents Skin Damage
- Easy Do-It-Yourself Installation
- Eliminate Large/Bulky Skimmers



DG260-TSL With Cover



DG260-TSL Without Cover

## CNC Indexing and Feeding Technologies Premier Product Lines include:

CNC Indexing & Feeding Technologies is a premier value added importer/supplier of quality machine tool accessories. We strive to offer manufacturers access to quality machine tool accessories that will increase their productivity and profitability. CNC Indexing provides first class after sales service and support.

- TJR ROTARY TABLES AND INDEXERS
- CNC INDEXING HIGH PRESSURE COOLANT SYSTEMS
- CNC INDEXING BAR FEEDERS, LOADERS & GANTRY SYSTEMS
- WELLTECH OIL SKIMMERS
- RÖHM WORKHOLDING
- AR FILTRAZIONI AIR FILTRATION SYSTEMS

Make your machining centers and lathes more productive and profitable by adding our high quality machine tool accessories.

The knowledgeable staff at CNC Indexing & Feeding Technologies can help in selecting the right product to meet your manufacturing needs. If our standard products do not meet your requirements, we also offer custom solutions designed around your specific application.

Can't find a machine tool accessory to fit your needs?  
Ask us, we have many sources for machine tool accessories worldwide and may be able to help.

Contact CNC Indexing Today

## CNC INDEXING & FEEDING TECHNOLOGIES



SCAN ME

7944 Innovation Way, Suite B,  
Mason OH 45040  
Phone 513.770.4200  
www.cncindexing.com  
sales@cncindexing.com

◀ VISIT OUR WEBSITE

# CNC INDEXING & FEEDING TECHNOLOGIES

WWW.CNCINDEXING.COM | SALES@CNCINDEX.COM



**TJR**  
Rotary table  
Rotary Tables & Indexers



**RÖHM**  
driven by technology  
Workholding



**AR FILTRAZIONI**  
CHANGES IN THE AIR  
Air Filtering Systems



**CNC INDEXING  
& FEEDING TECHNOLOGIES**  
High Pressure Coolant Units

YOUR CNC ACCESSORIES PARTNER



## TRACER

### 6'-12' Hydrodynamic Magazine Bar Feeders & 4'-6' Short Loaders

#### TRACER BAR FEEDER SERIES

- Minibar: .8mm - 12mm Bar Ø
- Tracer 20: 3mm - 26mm Bar Ø
- Tracer 32V: 5mm - 38mm Bar Ø
- Tracer 51V: 5mm - 56mm Bar Ø
- Tracer 65V/80V: 10mm - 80mm Bar Ø

#### TRACER SHORT BAR LOADER SERIES

- Tracer V-65E/V-65LE: 5mm - 65mm Bar Ø
- Tracer Vs-65E/Vs-65LE: 5mm - 65mm Bar Ø
- Tracer Vs-80L: 8mm - 80mm Bar Ø
- Tracer Vs-105XL: 5mm - 105mm Bar Ø
- Pneumatic & Servo Models Available

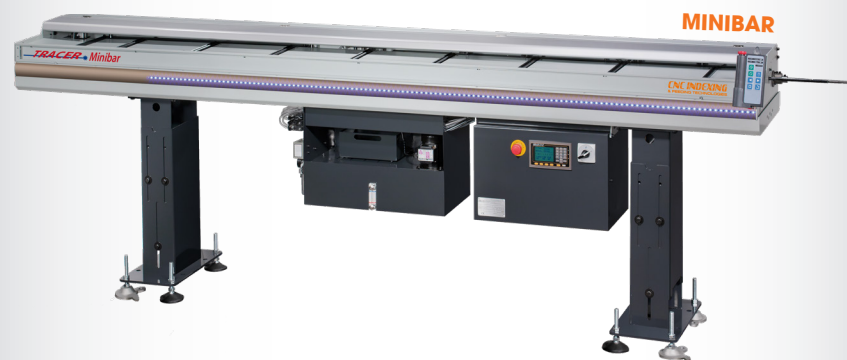

MINIBAR



TRACER 20



TRACER 65V



V-65E / Vs-65LE / Vs-80L



Vs-105XL

## CNC INDEXING & FEEDING TECHNOLOGIES



HPC-1000, 1,500 & 2,000



HPC-400



HPO-2000

**Increase Productivity. Improve Quality. Reduce Manufacturing Costs.**

- HPC-400 - 8 GPM - 3HP Gear Pump, Adjustable pressure 75-427t PSI
- HPC-1000 - 8 GPM - 7.5HP Gear Pump, Adjustable pressure 75-1,000 PSI
- HPC-1500 - 8 GPM - 7.5HP Gear Pump, Adjustable pressure 75-1,500 PSI
- HPC-2000 - 6 GPM - 10HP Gear Pump, Adjustable pressure 75-2,000 PSI
- HPO-2000 - 2000 PSI High Pressure Oil with 8 Ports
- Installation Upon Request • Customized HPC Systems Available



CHANGE IS IN THE AIR



#### AR FILTRAZIONI - AIR FILTRATION SYSTEM

- 5 Filter Stages = Less maintenance costs
- Cleaner Facilities = Increased productivity
- Cleaner air = Better employee health & well-being improves moral & employee/management relations
- Cleaner air = Less risk of fire
- Cleaner air = Improves measuring equipment results
- Cleaner air = Reduction of airborne radicals that effect machinery surfaces & internal components
- Improves employee relations with management
- Protects the environment both inside & out

## TJR Rotary table



**FAR/FHR SERIES** Shown: FAR-210B  
CNC TILT DUAL/ SINGLE ARM / DUAL ARM / SINGLE AXIS HYDRAULIC OR PNEUMATIC BRAKE  
Ø 125 - 650mm | 4.92" - 25.6"



**AR LEFT & RIGHT SERIES**  
Shown: AR-210L  
STD. PNEUMATIC BRAKE  
Ø 125 - 255mm | 4.92" - 10.03"

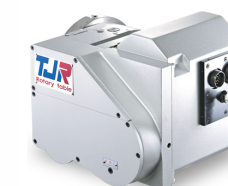

**AR-B SERIES**  
Shown: AR-210B  
REAR MOTOR MOUNT  
Ø 125 - 250mm | 4.92" - 9.84"



**AD SERIES**  
Shown: AD-260IB  
DIRECT DRIVE MOTOR  
Ø 170mm - 250mm | 6.69" - 9.84"



**AR SERIES**  
Shown: AR-170-3W  
2, 3, & 4 MULTI-SPINDLES  
Ø 125mm - 210mm | 4.92" - 8.27"

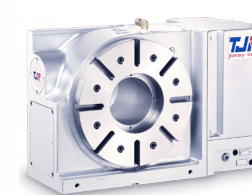

**HR SERIES** Shown: HR-320  
STD. HYDRAULIC BRAKE  
Ø 210 - 800mm | 8.26" - 31.9"

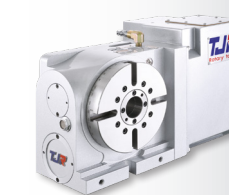

**ROLLER GEAR CAM**  
Shown: RC-7R  
Ø 170mm - 320mm | 6.69" - 12.60"

## GANRO CNC ROTARY TABLE

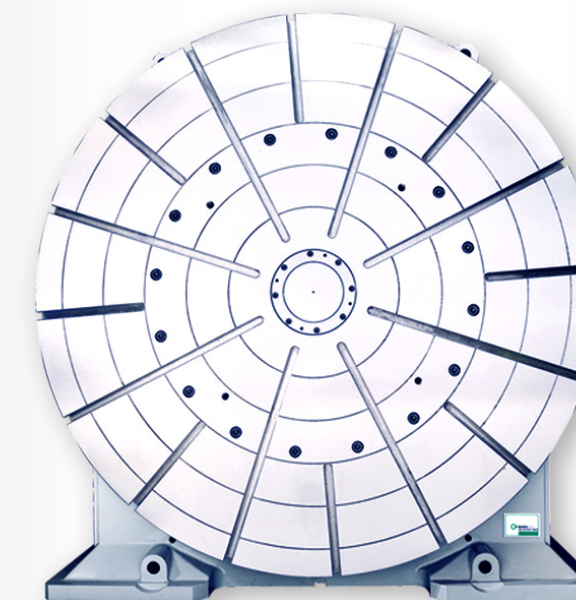

**LARGE ROTARY TABLE**  
Ø 1016mm - 2489.2mm | 40" - 98" Table  
Customized Faceplate's Available!